

The HEMLOCK - 24 x 24 Garage

Model # HE2424G12 - 12/12 Pitch

10' - 0" WALL



(AS DESIGNED)



NUMBER	DATE	REVISION	DESCRIPTION
1	9/2020	SH	Initial Setup
2	8/2020	SH	Launch Review
2	11/2021	SH	Upgrade 2021
1	10/2022	SH	Upgrade 2022



The HEMLOCK
24 x 24 Garage : 12/12
Gable Facing Doors

DRAWINGS PROVIDED BY:
Get My Garage
sheldon@fieldstonedesign.com
Custom Drawings Available

DATE:

12/22/2022

SCALE:

SHEET:

A - 1



" OPTIONS ARE ENDLESS "

LOCATION : _____
ACCOUNT MANAGER : _____

CLIENT NAME : _____
TOWN : _____

The HEMLOCK - 24 x 24 Garage

Model # HE2424G12 - 12/12 Pitch

10' - 0" WALL

GARAGE SPECIFICATIONS

(AS DRAWN)

SIZE = 24'-0" x 24'-0"
 CODE = IRC 2015 Minimum
 Alternate : _____
 LOADS = Check Local CE

FOUNDATION = Options Available

WALL HEIGHT = 10'-0"
 WALL FRAME = 2x6 KD - Open Stud
 HEADERS = 2x10 and LVL
 SHEATHING = 1/2" Min - Wall

ROOF = Truss System - Open Ceiling
 ROOF PITCH = 12/12
 O-HANG SIZE = 12"
 SHEATHING = 5/8" Min

SIDING = Vinyl Siding
 ROOFING = Architectural Shingles
 SOFFETS = Vinyl
 TRIMS = Aluminum Coil Wrapped

WINDOWS = Vinyl
 DOORS = Insulated
 GARAGE DOORS = Insulated

2nd LEVEL STORAGE
 Stair Access

CODE :
 - - Maine - - GMG90061

MATERIALS CALCULATIONS IS A GUIDE
 Depending on Personal Choices Additional
 or alternate Materials will be needed and
 should be discussed with the General Contractor
 and the Building Supplier Representative.



" OPTIONS ARE ENDLESS "

MATERIAL CALCULATIONS

(AS DRAWN)

96 Lf Sill Sealer
 96 Lf 2x6 PT Sill Plate
 340 Lf 2x6 KD Plate
 96 Ea 2x6x10 KD Stud
 24 Ea 2x6x8 KD Stud
 72 Lf 2x10 KD Header
 54 Lf 11 7/8" LVL Header
 1170 Sf 1/2" Sheathing Walls
 1170 Sf House Wrap - Protect
 1 System Roof Trusses - Attic Truss
 52 Lf 2x6 KD Sub Fascia
 222 Lf 2x6 KD Rake Frame
 300 Lf 2x4 Kd Lateral/ Diagonal Bracing
 962 Sf 5/8" Roof Sheathing
 288 Sf 3/4" Floor Sheathing
 126 Lf Drip Edge
 52 Lf Ice and Water Shield (36" Coverage)
 800 Sf 15# Felt Paper - Protect
 26 Lf Ridge Vent - Optional
 962 Sf Architectural Roof Shingle
 40 Lf Outside Corner - Vinyl
 96 Lf Starter Strip - Vinyl
 80 Lf J-Channel - Doors
 74 Lf J-Channel - Rake
 52 Lf J-Chan/ Undersill - Eave
 74 Sf Solid Soffit - Rake
 52 Sf Vented/ Solid - Eave
 4 Roll Coil Stock - Verify / Option - Trim
 220 Lf Exterior Trim - Optional
 1170 Sf Vinyl Siding
 60 Lf 2x10/12 KD - Stair Stringers
 30 Lf 2x6 KD - Platform Frame
 106 Sf 3/4" Sheathing - Sub Tread

(AS DRAWN)

Window and Door Schedule

W1 - 32"x52" Double Hung
 D1 - 3'-0" x 6'-8" Entry Door
 D2 - 8'-0" x 8'-0" Garage Door

Quality, Brand and Features by Others - TBD
 Consult Manufacturer for Rough Openings

PLEASE CONSULT YOUR BUILDING SUPPLY PROFESSIONAL
 For Options, Desired Modifications, and Alternate Product Availability

MATERIAL DATA SOURCE

DATA SOURCE

Intended as a Guide for Alternate Products
 KEY : Lf = Lineal Foot : Sf = Square Foot : Ea = Each
 CE = Code Enforcement : GSL = Ground Snow Load

96 Lf Exterior Wall @ 10'-0"
 24 Lf Exterior Wall @ 8'-0"
 1170 Sf Exterior Sheathing/ Siding
 962 Sf Roof Sheathing/ Roofing
 26 Lf Ridge
 74 Lf Rake
 52 Lf Eave
 220 Lf Win/ Door/ G Door Trim Ext

STRUCTURAL NOTES

72 Lf Win/ Door Headers @ 2x10
 54 LF G-Door Headers @ 11 7/8" LVL

RIDGE : 23' - 6" +/-

STRUCTURAL NOTES
 Based on Northern Maine Load Conditions
 Loading = 100# GSL : 100# Wind

Consult your Local Supplier for Reductions



REVISION TABLE	NUMBER	DATE	REVISION BY	DESCRIPTION
	1	9/2020	SH	Initial Setup
	2	8/2020	SH	Launch Review
	2	11/2021	SH	Upgrade 2021
	1	10/2022	SH	Upgrade 2022



The HEMLOCK
 24 x 24 Garage : 12/12
 Gable Facing Doors

DRAWINGS PROVIDED BY:
 Get My Garage
 sheldon@fieldstonedesign.com
 Custom Drawings Available

DATE:
 12/22/2022

SCALE:

SHEET:

A - 2

The HEMLOCK - 24 x 24 Garage

Model # HE2424G12 - 12/12 Pitch

ATTENTION CONSTRUCTION PROFESSIONALS
Use this Page for Modifications, Additions, Subtractions and Estimation Notes



10' - 0" WALL

NUMBER	DATE	REVISED BY	DESCRIPTION
1	9/2020	SH	Initial Setup
2	8/2020	SH	Launch Review
2	11/2021	SH	Upgrade 2021
1	10/2022	SH	Upgrade 2022



The HEMLOCK
24 x 24 Garage : 12/12
Gable Facing Doors

DRAWINGS PROVIDED BY:
Get My Garage
sheldon@fieldstonedesign.com
Custom Drawings Available

DATE:

12/22/2022

SCALE:

SHEET:

A - 3



" OPTIONS ARE ENDLESS "

ESTIMATION WORK SHEET

Revision and Order Notes

The HEMLOCK - 24 x 24 Garage

Model # HE2424G12 - 12/12 Pitch

PLEASE CONSULT YOUR LOCAL CODE ENFORCEMENT or CONTRACTOR
Requisites for Foundations Vary from one Municipality to another.



10' - 0" WALL

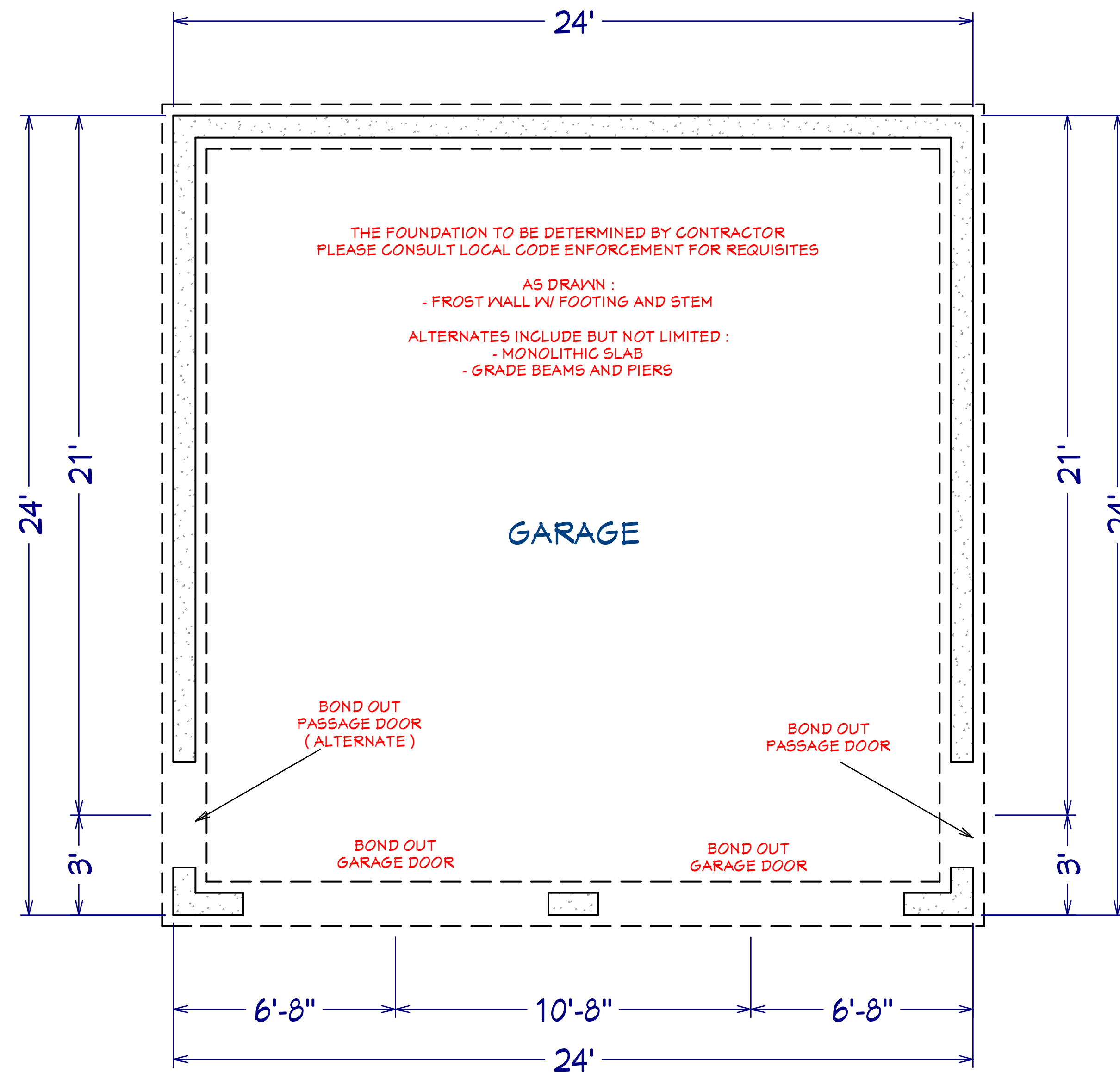

SLAB w/ FROST WALL

MONOLITHIC SLAB : Check Here _____

Slab Thickness : _____
 Honch Thickness : _____
 Honch Width : _____
 Concrete PSI : _____
 Rebar / Mesh : _____

With STEM : Check Here _____
 Stem Height : _____
 Stem Type : _____
 Concret PSI : _____
 Rebar : _____

SLAB w/ FROST WALL : Check Here _____

Slab Thickness : _____
 Honch Thickness : _____
 Honch Width : _____
 Concrete PSI : _____
 Rebar / Mesh : _____

With STEM : Check Here _____
 Stem Height : _____
 Stem Type : _____
 Concret PSI : _____
 Rebar : _____

NUMBER	DATE	REVISION	DESCRIPTION
1	9/2020	SH	Initial Setup
2	8/2020	SH	Launch Review
2	11/2021	SH	Upgrade 2021
1	10/2022	SH	Upgrade 2022



The HEMLOCK
24 x 24 Garage : 12/12
Gable Facing Doors

DRAWINGS PROVIDED BY:
Get My Garage
sheldon@fieldstonedesign.com
Custom Drawings Available

DATE:

12/22/2022

SCALE:

SHEET:

A - 4



" OPTIONS ARE ENDLESS "

FLOOR LAYOUT Foundation

3/8" - 1'-0" Scale
Printed at ARCH D

The HEMLOCK - 24 x 24 Garage

Model # HE2424G12 - 12/12 Pitch

10' - 0" WALL

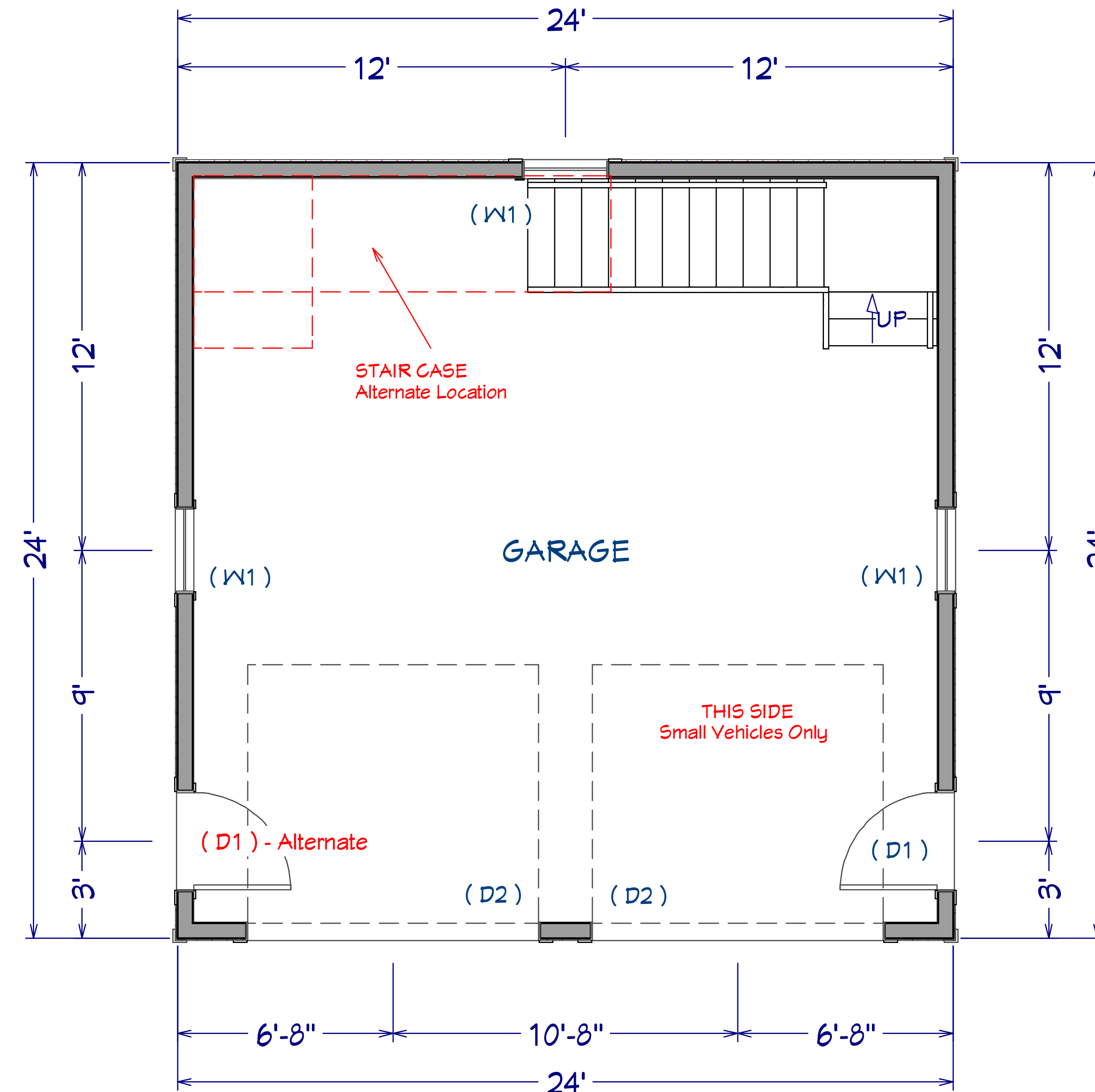

" OPTIONS ARE ENDLESS "

FLOOR LAYOUT Lower Level

3/8" - 1'-0" Scale
Printed at ARCH D



NUMBER	DATE	REVISION	DESCRIPTION
1	9/2020	SH	Initial Setup
2	8/2020	SH	Launch Review
2	11/2021	SH	Upgrade 2021
1	10/2022	SH	Upgrade 2022



The HEMLOCK
24 x 24 Garage : 12/12
Gable Facing Doors

DRAWINGS PROVIDED BY:
Get My Garage
sheldon@fieldstonedesign.com
Custom Drawings Available

DATE:

12/22/2022

SCALE:

SHEET:

A - 5

The HEMLOCK - 24 x 24 Garage

Model # HE2424G12 - 12/12 Pitch

10' - 0" WALL

STAIR CASE
Alternate Location

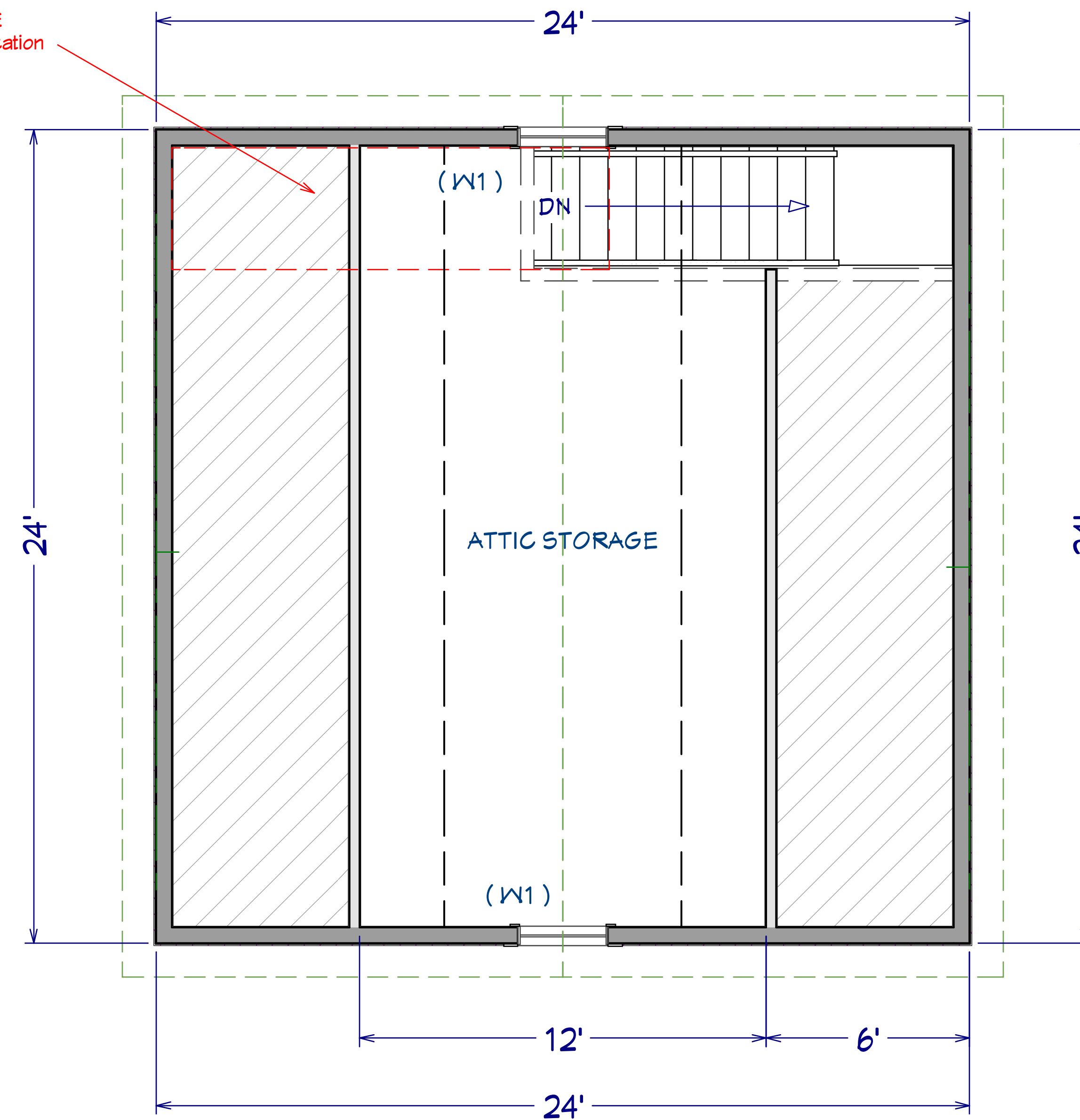

" OPTIONS ARE ENDLESS "

FLOOR LAYOUT Upper Level

3/8" - 1'-0" Scale
Printed at ARCH D



NUMBER	DATE	REVISION	DESCRIPTION
1	9/2020	SH	Initial Setup
2	8/2020	SH	Launch Review
2	11/2021	SH	Upgrade 2021
1	10/2022	SH	Upgrade 2022



The HEMLOCK
24 x 24 Garage : 12/12
Gable Facing Doors

DRAWINGS PROVIDED BY:
Get My Garage
sheldon@fieldstonedesign.com
Custom Drawings Available

DATE:

12/22/2022

SCALE:

SHEET:

A - 6

The HEMLOCK - 24 x 24 Garage

Model # HE2424G12 - 12/12 Pitch

10' - 0" WALL



FRONT ELEVATION

1/4" - 1'-0" Scale
Printed at ARCH D

WALL HEIGHT = 10'-0"
WALL FRAME = 2x6 KD
HEADERS = 2x10 and LVL
SHEATHING = 1/2" Min

ROOF = Truss System
ROOF PITCH = 12/12
O-HANG SIZE = 12"
SHEATHING = 5/8" Min

SIDING = Vinyl Siding
ROOFING = Architectural Shingles
SOFFETS = Vinyl
TRIMS = Aluminum Coil Wrapped

WINDOWS = Vinyl
DOORS = Insulated
GARAGE DOORS = Insulated

2nd LEVEL STORAGE
Stair Access



NUMBER	DATE	REVISION	DESCRIPTION
1	9/2020	SH	Initial Setup
2	8/2020	SH	Launch Review
2	11/2021	SH	Upgrade 2021
1	10/2022	SH	Upgrade 2022



The HEMLOCK
24 x 24 Garage : 12/12
Gable Facing Doors

DRAWINGS PROVIDED BY:
Get My Garage
sheldon@fieldstonedesign.com
Custom Drawings Available

DATE:

12/22/2022

SCALE:

SHEET:

A - 7

12/12 PITCH

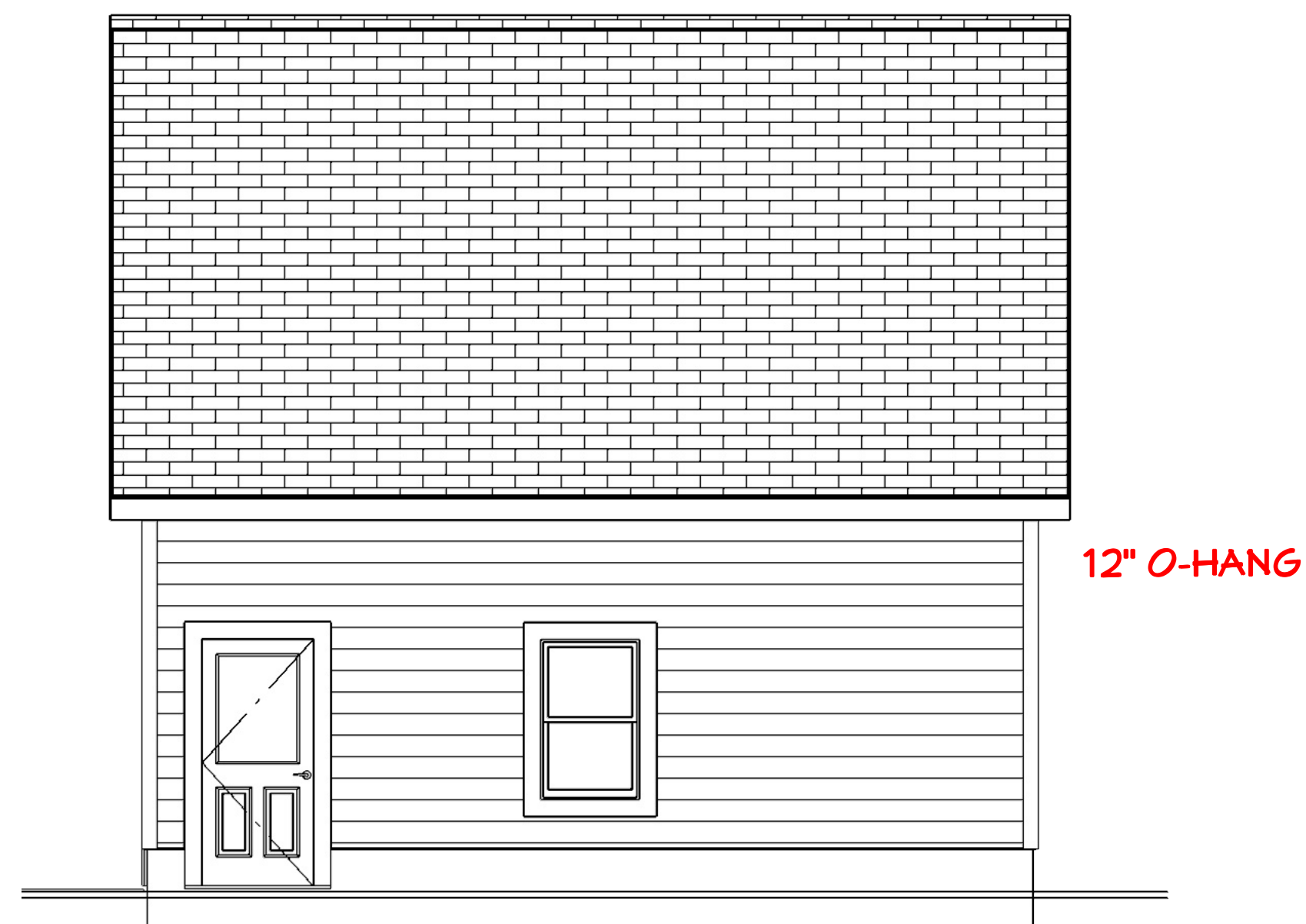

RIGHT ELEVATION

1/4" - 1'-0" Scale
Printed at ARCH D



" OPTIONS ARE ENDLESS "

The HEMLOCK - 24 x 24 Garage

Model # HE2424G12 - 12/12 Pitch

10' - 0" WALL



REAR ELEVATION

1/4" - 1'-0" Scale
Printed at ARCH D



" OPTIONS ARE ENDLESS "

WALL HEIGHT = 10'-0"
WALL FRAME = 2x6 KD
HEADERS = 2x10 and LVL
SHEATHING = 1/2" Min

ROOF = Truss System
ROOF PITCH = 12/12
O-HANG SIZE = 12"
SHEATHING = 5/8" Min

SIDING = Vinyl Siding
ROOFING = Architectural Shingles
SOFFETS = Vinyl
TRIMS = Aluminum Coil Wrapped

WINDOWS = Vinyl
DOORS = Insulated
GARAGE DOORS = Insulated

2nd LEVEL STORAGE
Stair Access

12/12 PITCH

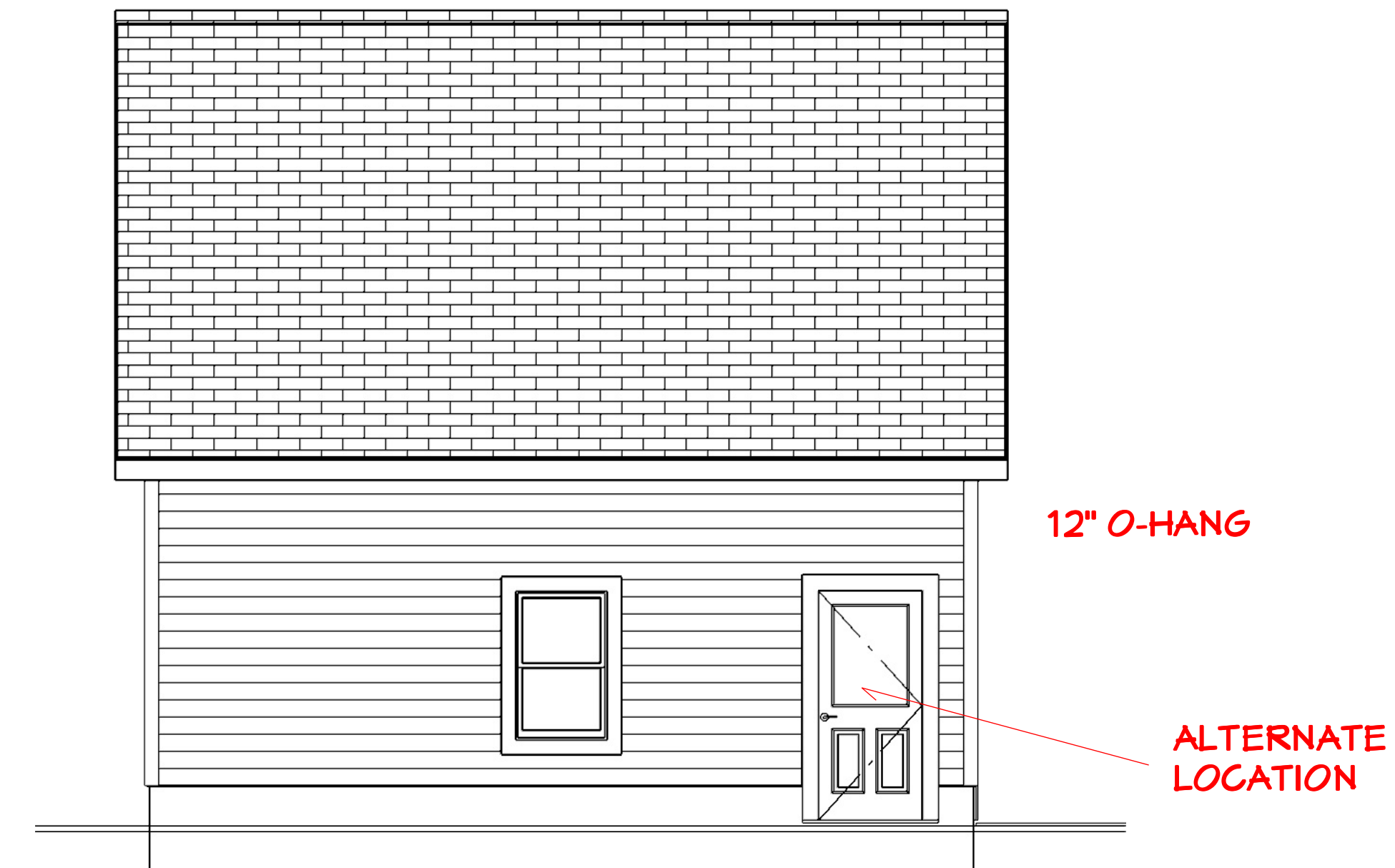

LEFT ELEVATION

1/4" - 1'-0" Scale
Printed at ARCH D



REVISION TABLE	NUMBER	DATE	REVISED BY	DESCRIPTION
1	9/2020	SH		Initial Setup
2	8/2020	SH		Launch Review
3	11/2021	SH		Upgrade 2021
4	10/2022	SH		Upgrade 2022



The HEMLOCK
24 x 24 Garage : 12/12
Gable Facing Doors

DRAWINGS PROVIDED BY:
Get My Garage
sheldon@fieldstonedesign.com
Custom Drawings Available

DATE:

12/22/2022

SCALE:

SHEET:

A - 8

The HEMLOCK - 24 x 24 Garage

Model # HE2424G12 - 12/12 Pitch

10' - 0" WALL

SR : 23' - 6" +/-

TOW : 18' - 10"

12/12 PITCH

SF : 10' - 10"

TOW : 10' - 0"

STEM : 1' - 0"

SLAB : 0.0

Upper Level
Storage Area

GRADE

BUILDING SECTION
As Drawn

ARCHITECTURAL SHINGLES
15# FELT PAPER
ICE AND WATER SHIELD
DRIP EDGE
5/8" SHEATHING
ROOF TRUSS SYSTEM
LATERAL AND DIAGONAL BRACING
CEILING - UNFINISHED

VINYL SIDING
VINYL TRIM
HOUSE WRAP
1/2" SHEATHING
2x6 KD FRAME
2x10/ LVL HEADERS
INTERIOR - UNFINISHED

FOUNDATION INFORMATION
See Page A-4
and Page A-11



NUMBER	DATE	REVISOR	DESCRIPTION
1	9/2020	SH	Initial Setup
2	8/2020	SH	Launch Review
3	11/2021	SH	Upgrade 2021
4	10/2022	SH	Upgrade 2022



The HEMLOCK
24 x 24 Garage : 12/12
Gable Facing Doors

DRAWINGS PROVIDED BY:
Get My Garage
sheldon@fieldstonedesign.com
Custom Drawings Available

DATE:

12/22/2022

SCALE:

SHEET:

A - 9



" OPTIONS ARE ENDLESS "

BUILDING SECTION

1/2" - 1'-0" Scale
Printed at ARCH D

The HEMLOCK - 24 x 24 Garage

Model # HE2424G12 - 12/12 Pitch

10' - 0" WALL

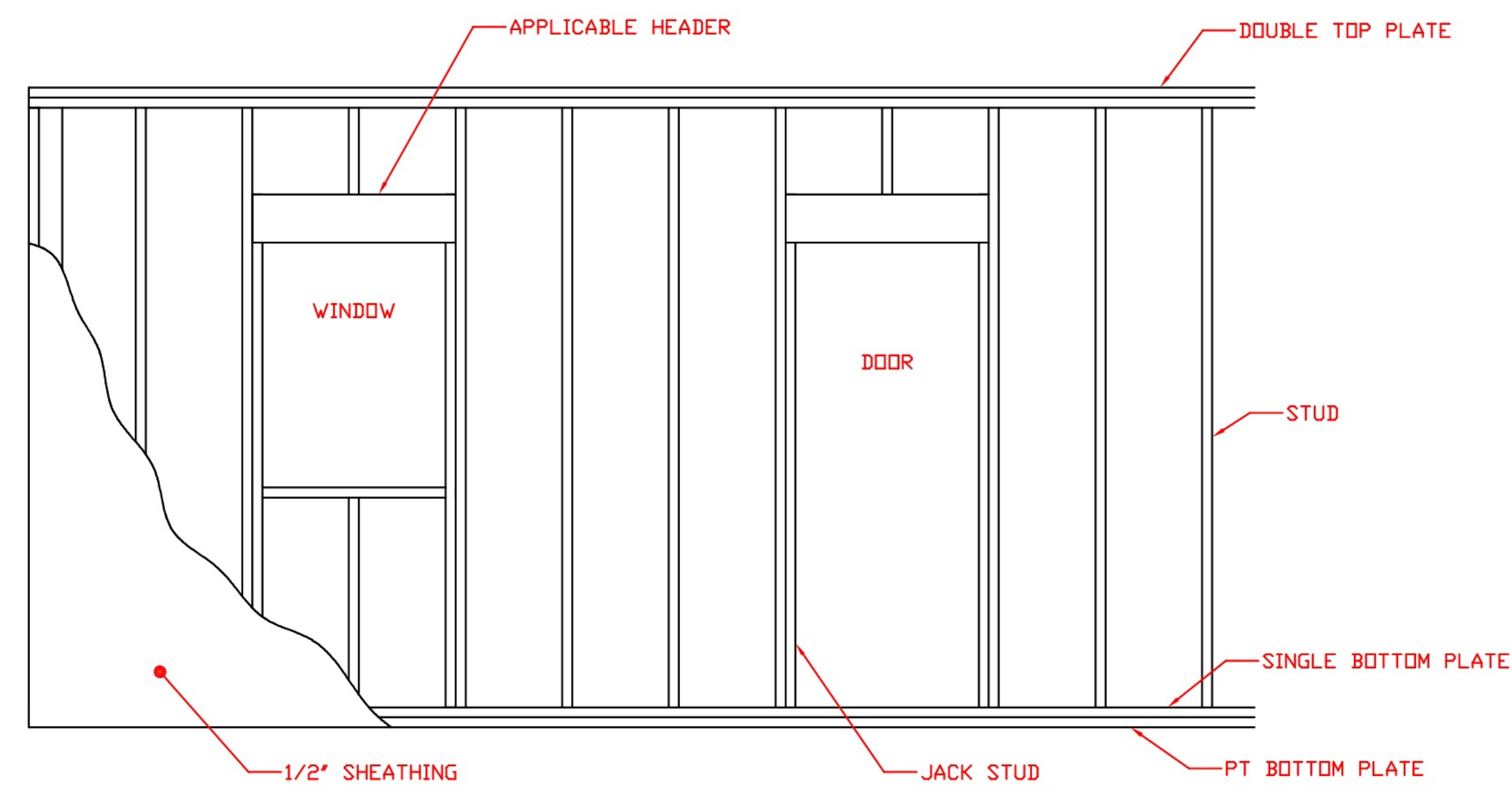

TYP. WALL DETAIL
NO SCALE

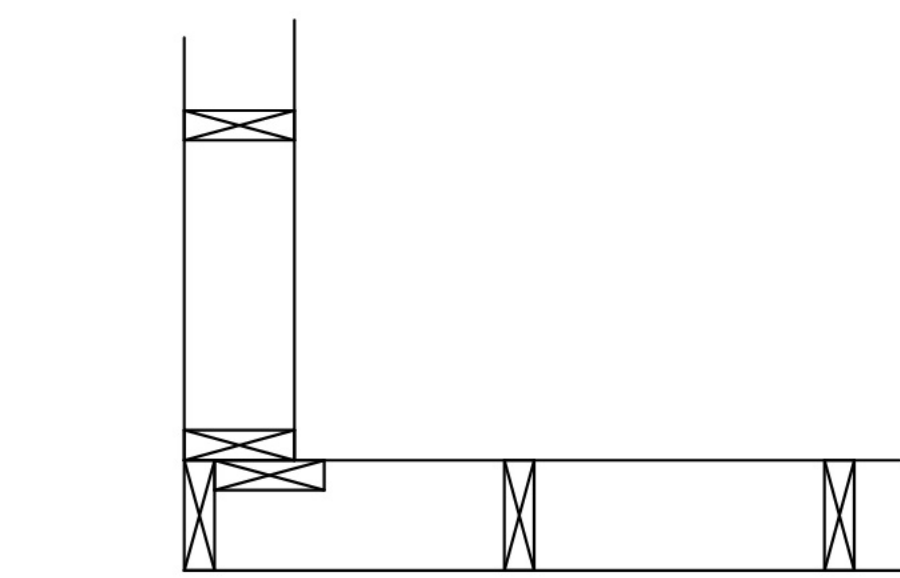

TYP. CORNER DETAIL
NO SCALE



" OPTIONS ARE ENDLESS "

TYPICAL WALL ASSEMBLY

NO SCALE



NUMBER	DATE	REVISION	DESCRIPTION
1	9/2020	SH	Initial Setup
2	8/2020	SH	Launch Review
2	11/2021	SH	Upgrade 2021
1	10/2022	SH	Upgrade 2022



The HEMLOCK
24 x 24 Garage : 12/12
Gable Facing Doors

DRAWINGS PROVIDED BY:
Get My Garage
sheldon@fieldstonedesign.com
Custom Drawings Available

DATE:

12/22/2022

SCALE:

SHEET:

A - 10

The HEMLOCK - 24 x 24 Garage

Model # HE2424G12 - 12/12 Pitch

10' - 0" WALL

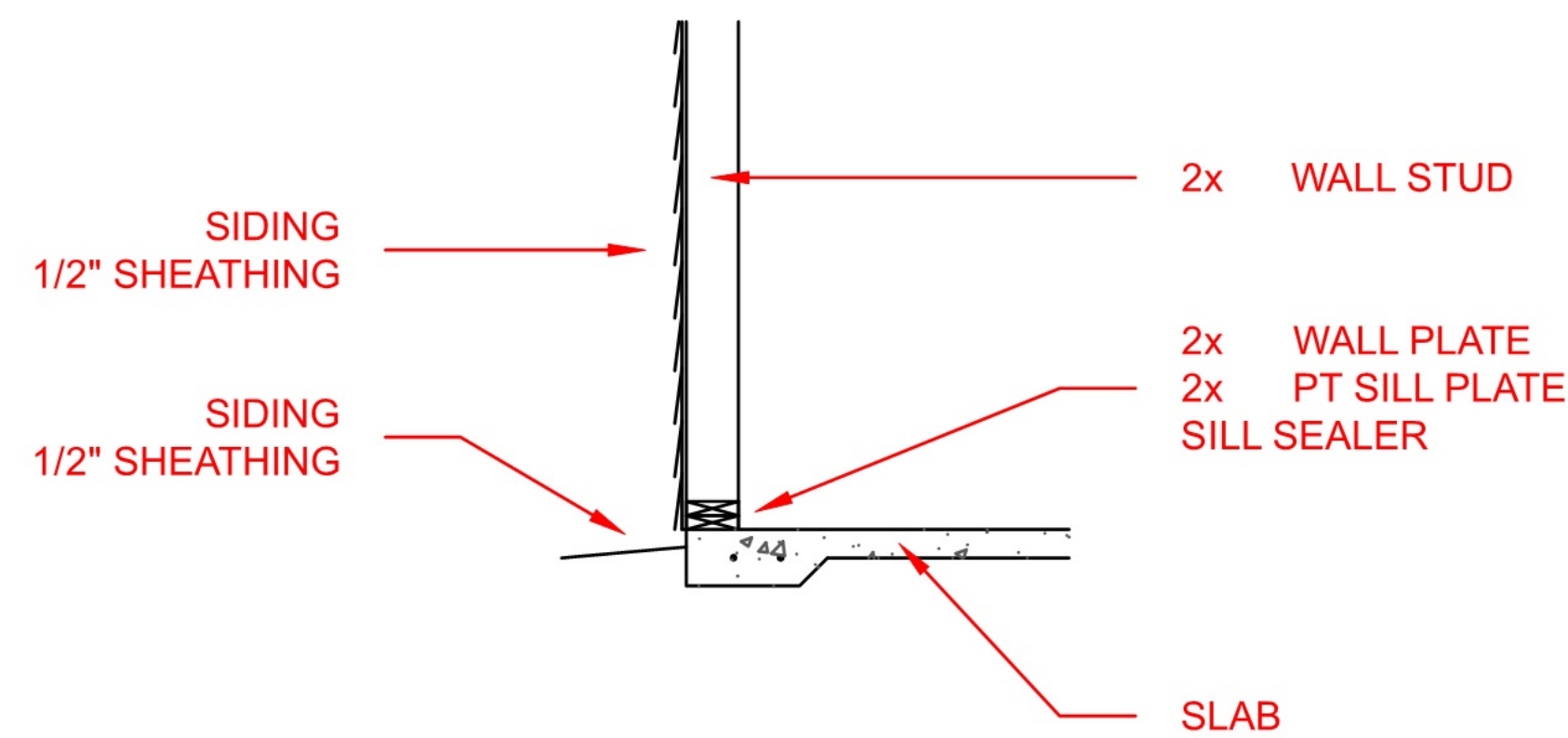

MONOLITHIC SLAB

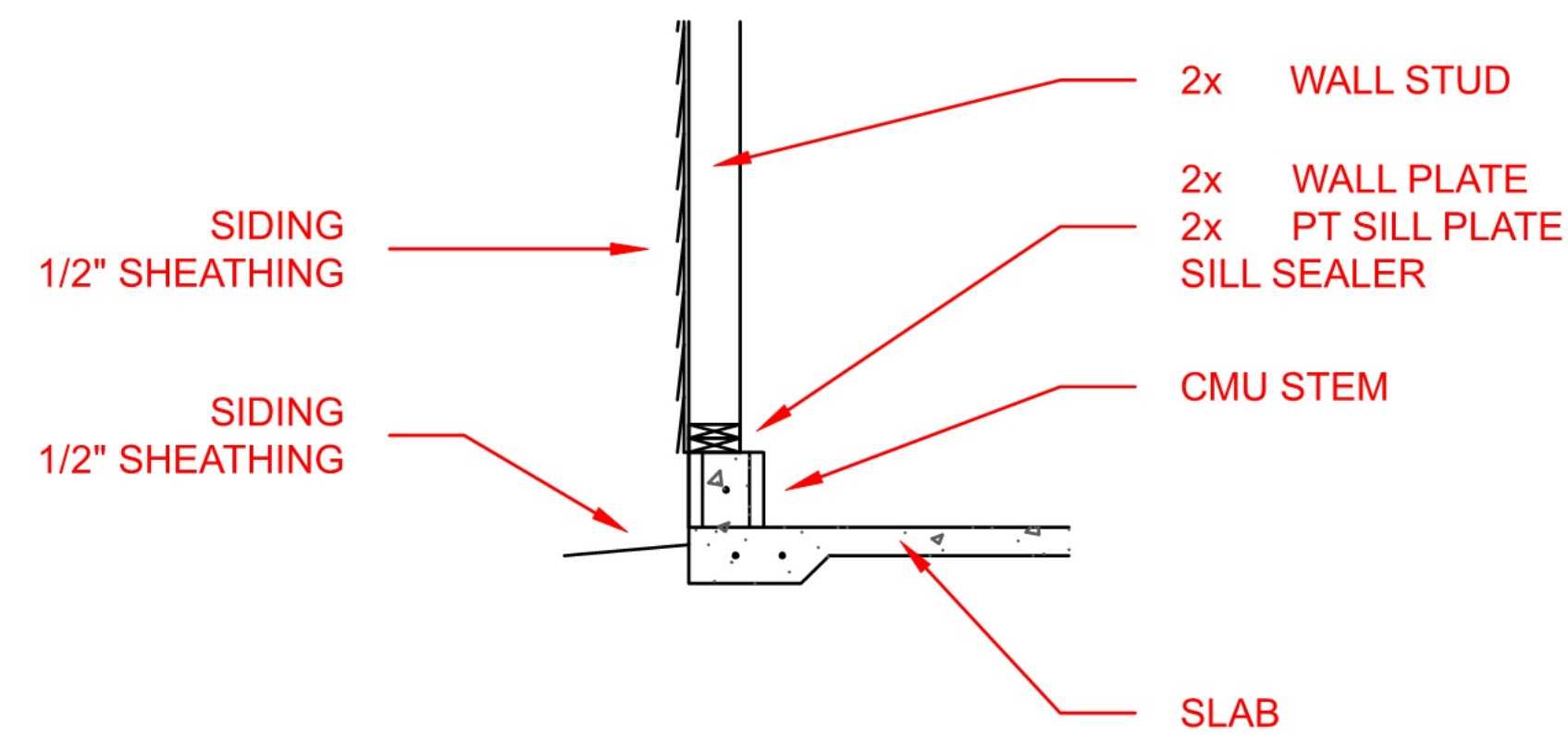

MONOLITHIC SLAB w/ STEM

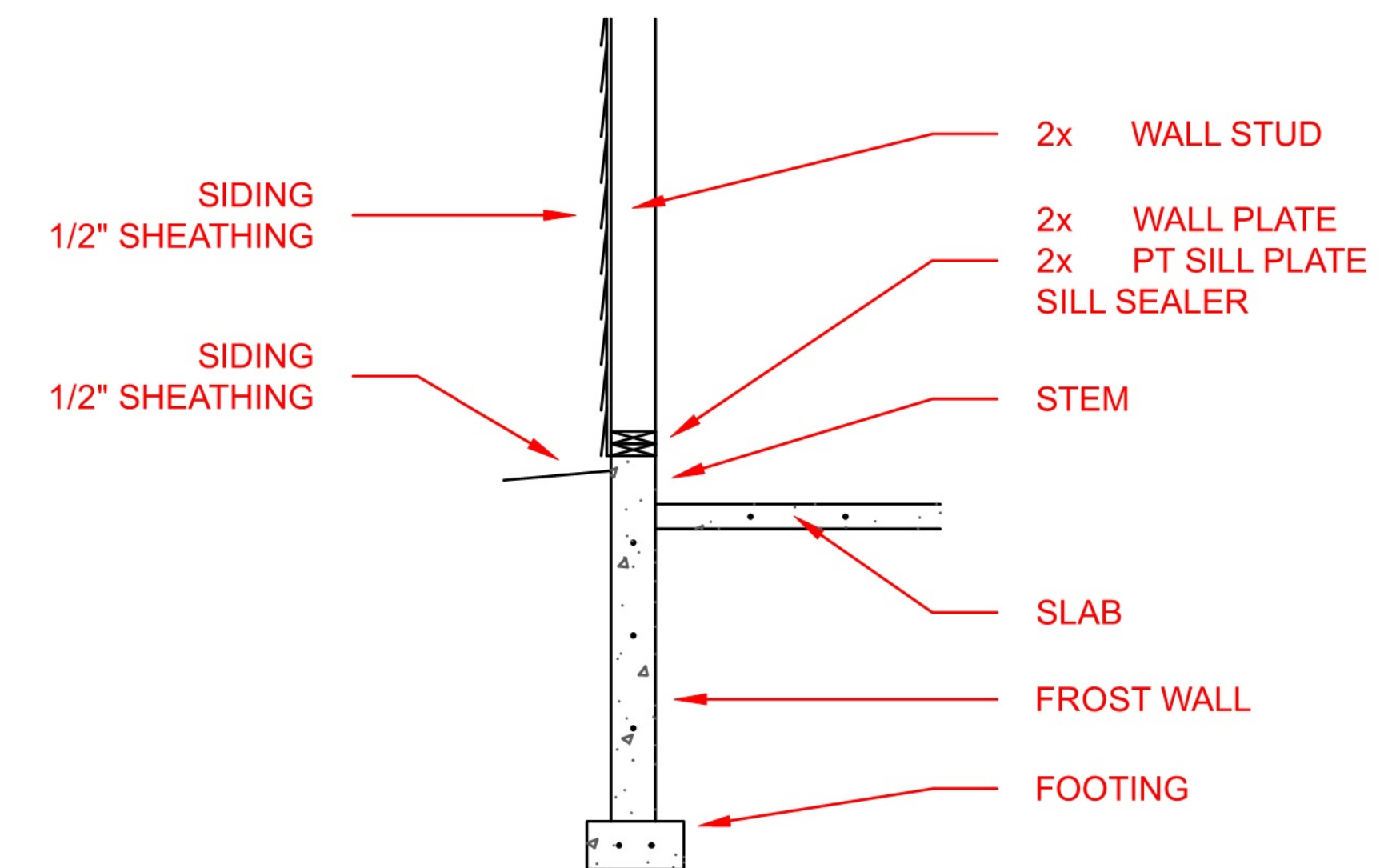

FOOTING w/ FROST WALL and STEM

FOUNDATION NOTES



" OPTIONS ARE ENDLESS "

FOUNDATION DETAILS

Choose Option
No Scale



REVISION TABLE	NUMBER	DATE	REVISED BY	DESCRIPTION
1	9/2020	SH		Initial Setup
2	8/2020	SH		Launch Review
2	11/2021	SH		Upgrade 2021
1	10/2022	SH		Upgrade 2022



The HEMLOCK
24 x 24 Garage : 12/12
Gable Facing Doors

DRAWINGS PROVIDED BY:
Get My Garage
sheldon@fieldstonedesign.com
Custom Drawings Available

DATE:

12/22/2022

SCALE:

SHEET:

A - 11

The HEMLOCK - 24 x 24 Garage

Model # HE2424G12 - 12/12 Pitch

10' - 0" WALL

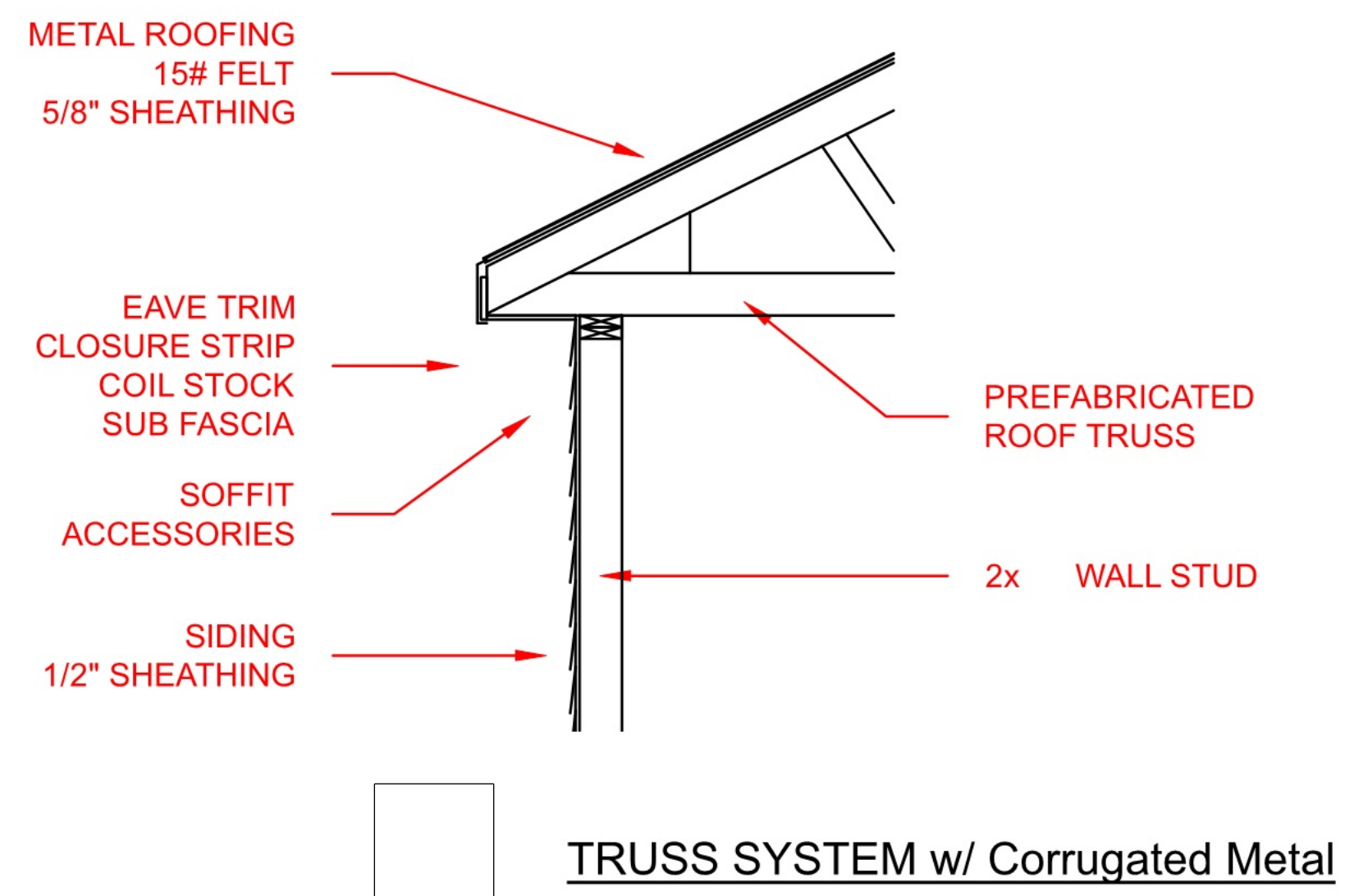
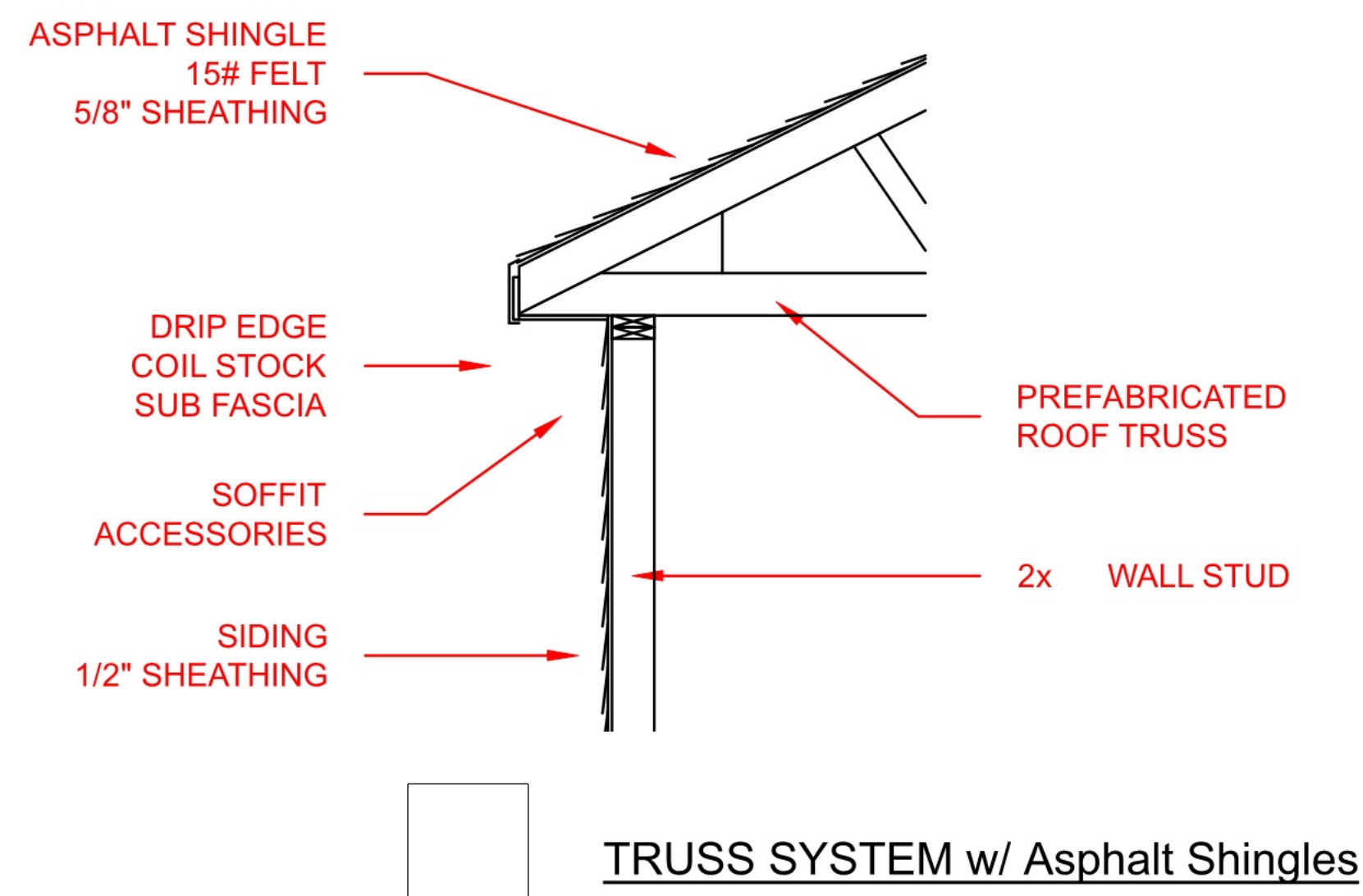
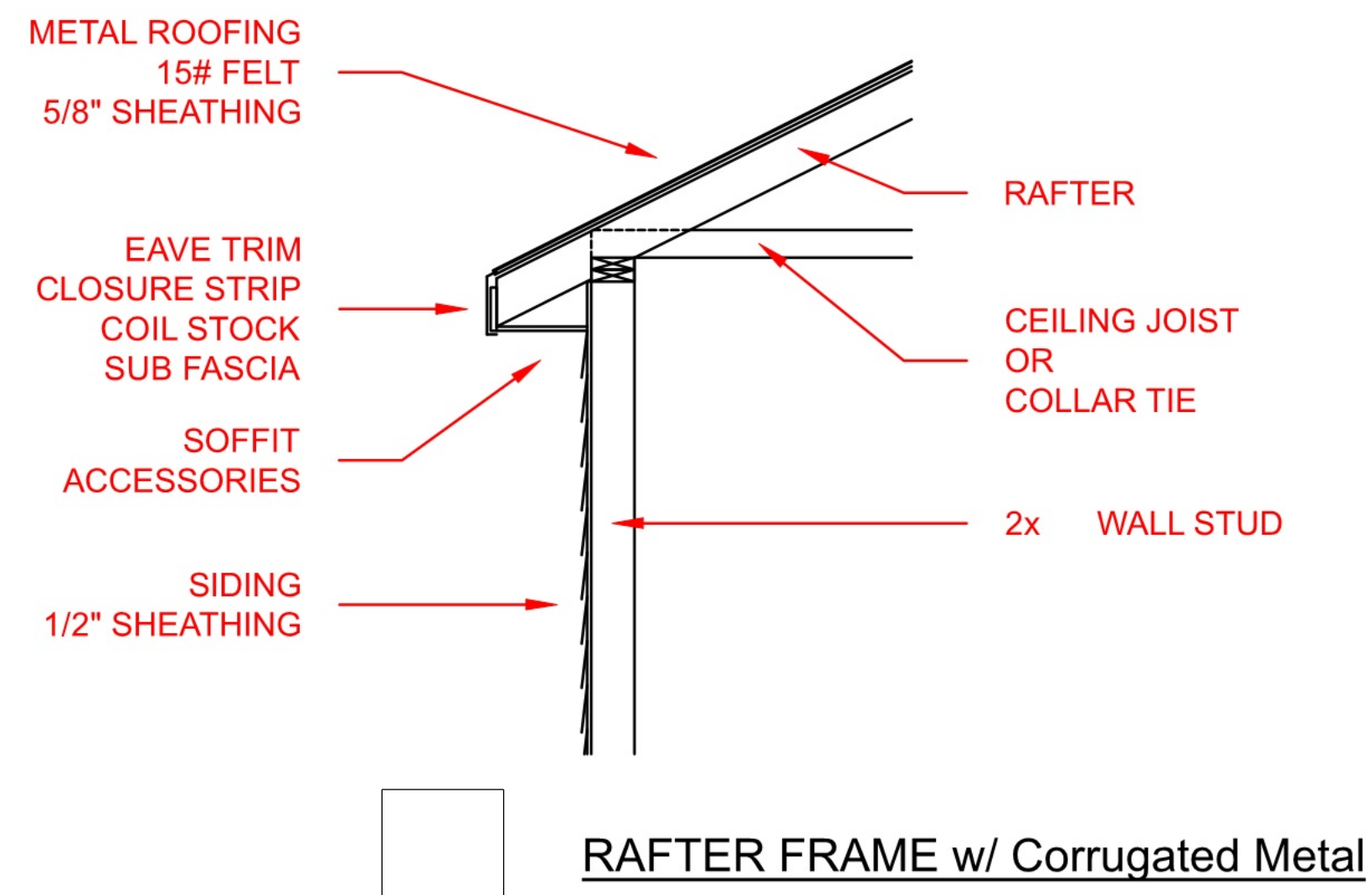
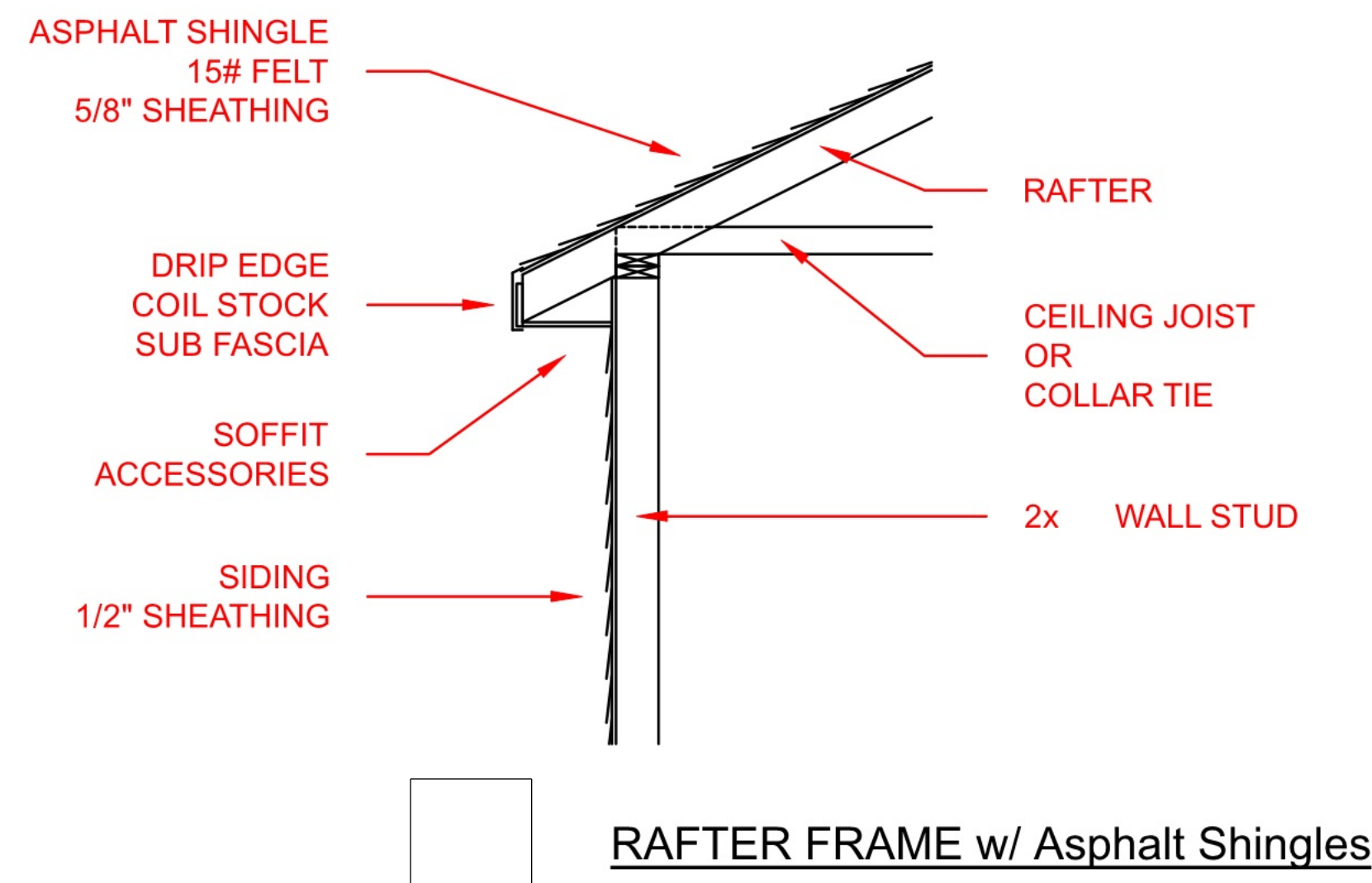

ROOF FRAMING NOTES



REVISION TABLE	NUMBER	DATE	REVISOR	DESCRIPTION
	1	9/2020	SH	Initial Setup
	2	8/2020	SH	Launch Review
	2	11/2021	SH	Upgrade 2021
	1	10/2022	SH	Upgrade 2022



The HEMLOCK
24 x 24 Garage : 12/12
Gable Facing Doors

DRAWINGS PROVIDED BY:
Get My Garage
sheldon@fieldstonedesign.com
Custom Drawings Available

DATE:

12/22/2022

SCALE:

SHEET:

A - 12



" OPTIONS ARE ENDLESS "

ROOF DETAILS

Choose Option
No Scale

The HEMLOCK - 24 x 24 Garage

Model # HE2424G12 - 12/12 Pitch

10' - 0" WALL

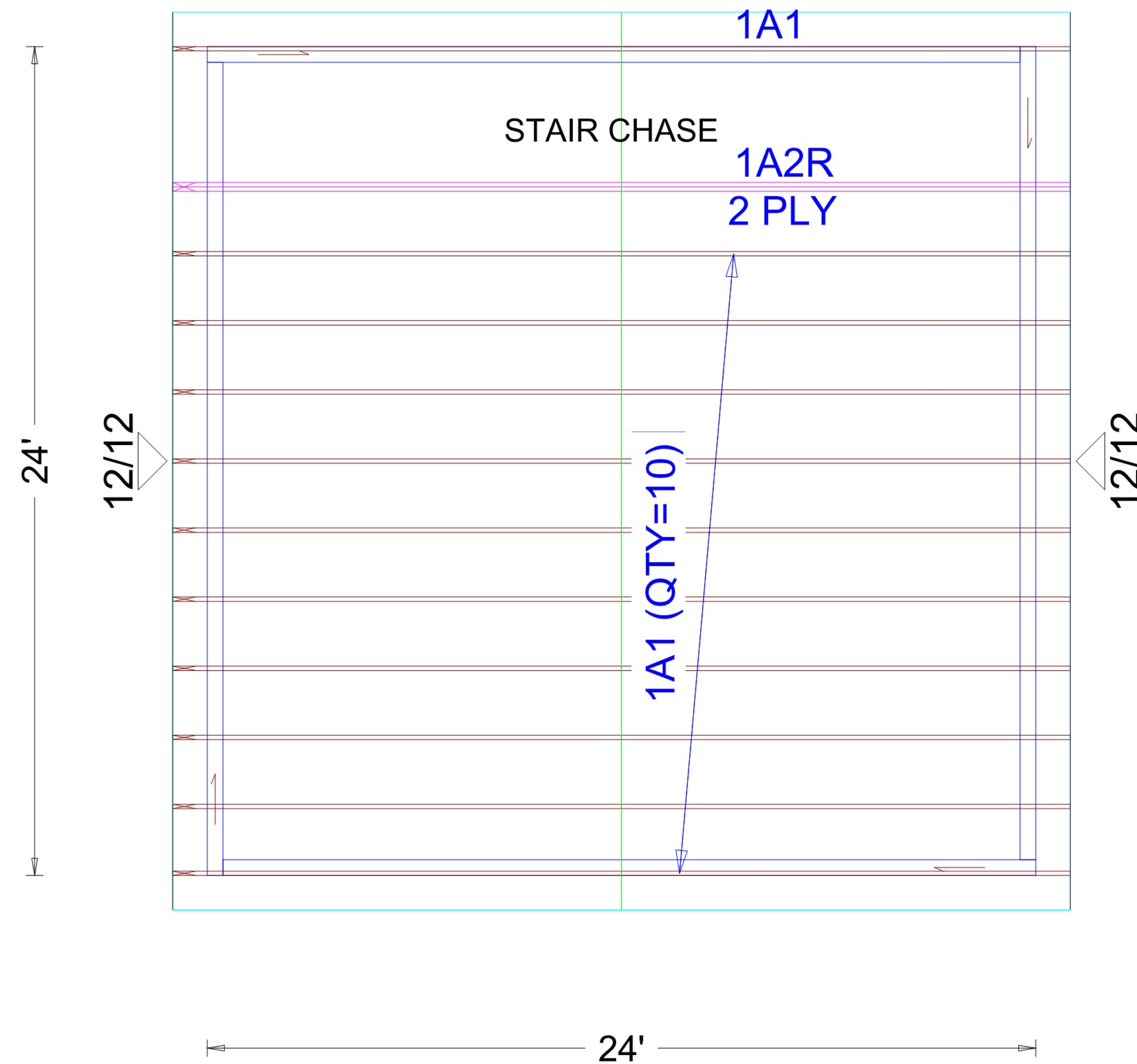

TRUSS LAYOUT

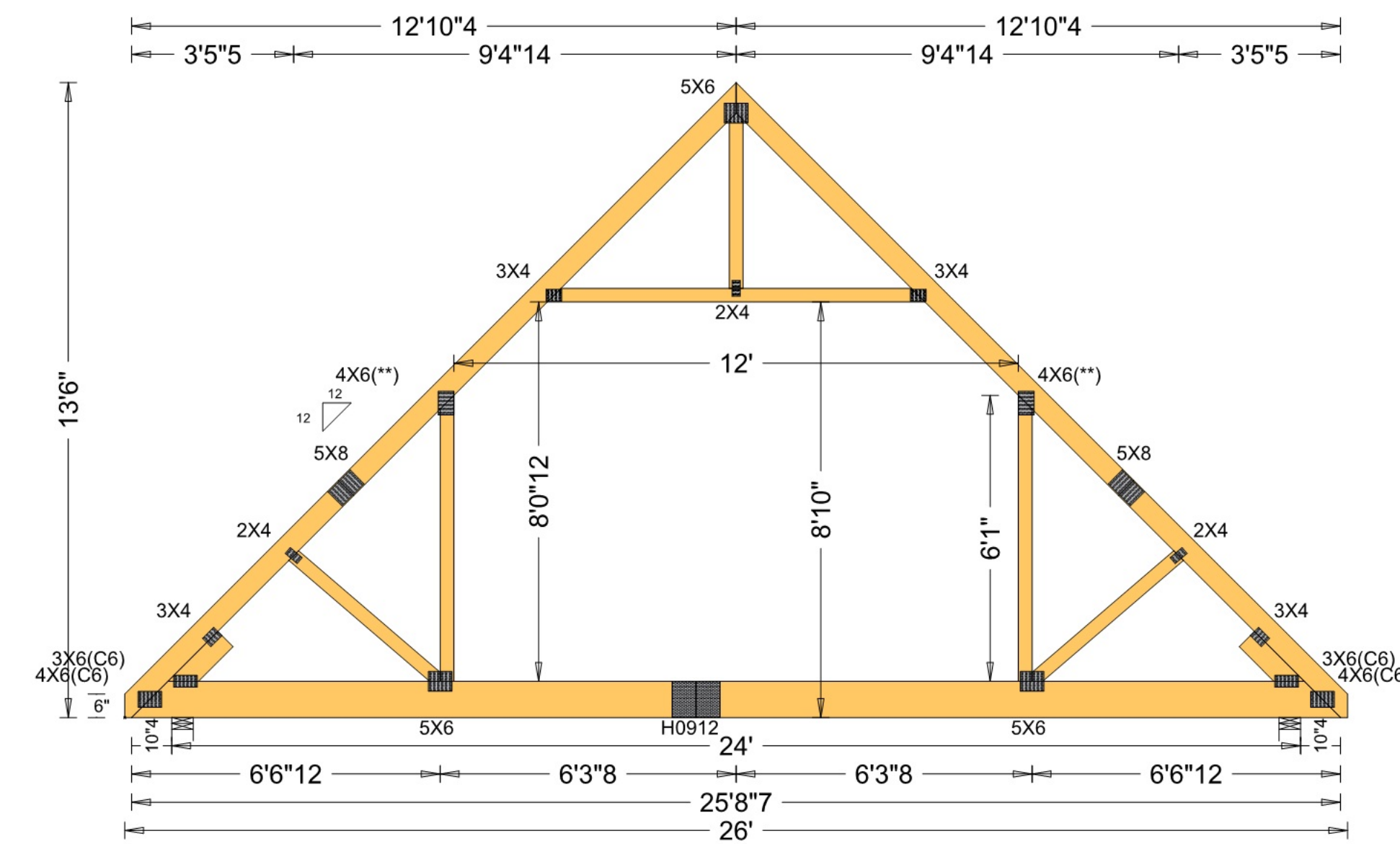

(1A1) - ATTIC TRUSS

ROOF TRUSS SYSTEM

Concept Drawing
No Scale



REVISION NUMBER	DATE	REVISION BY	DESCRIPTION
1	9/2020	SH	Initial Setup
2	8/2020	SH	Launch Review
2	11/2021	SH	Upgrade 2021
1	10/2022	SH	Upgrade 2022



The HEMLOCK
24 x 24 Garage : 12/12
Gable Facing Doors

DRAWINGS PROVIDED BY:
Get My Garage
sheldon@fieldstonedesign.com
Custom Drawings Available

DATE:

12/22/2022

SCALE:

SHEET:

A - 13



" OPTIONS ARE ENDLESS "

The HEMLOCK - 24 x 24 Garage

Model # HE2424G12 - 12/12 Pitch

10' - 0" WALL

THANK YOU SO MUCH

GET MY GARAGE
Random Design Ideas on this Page

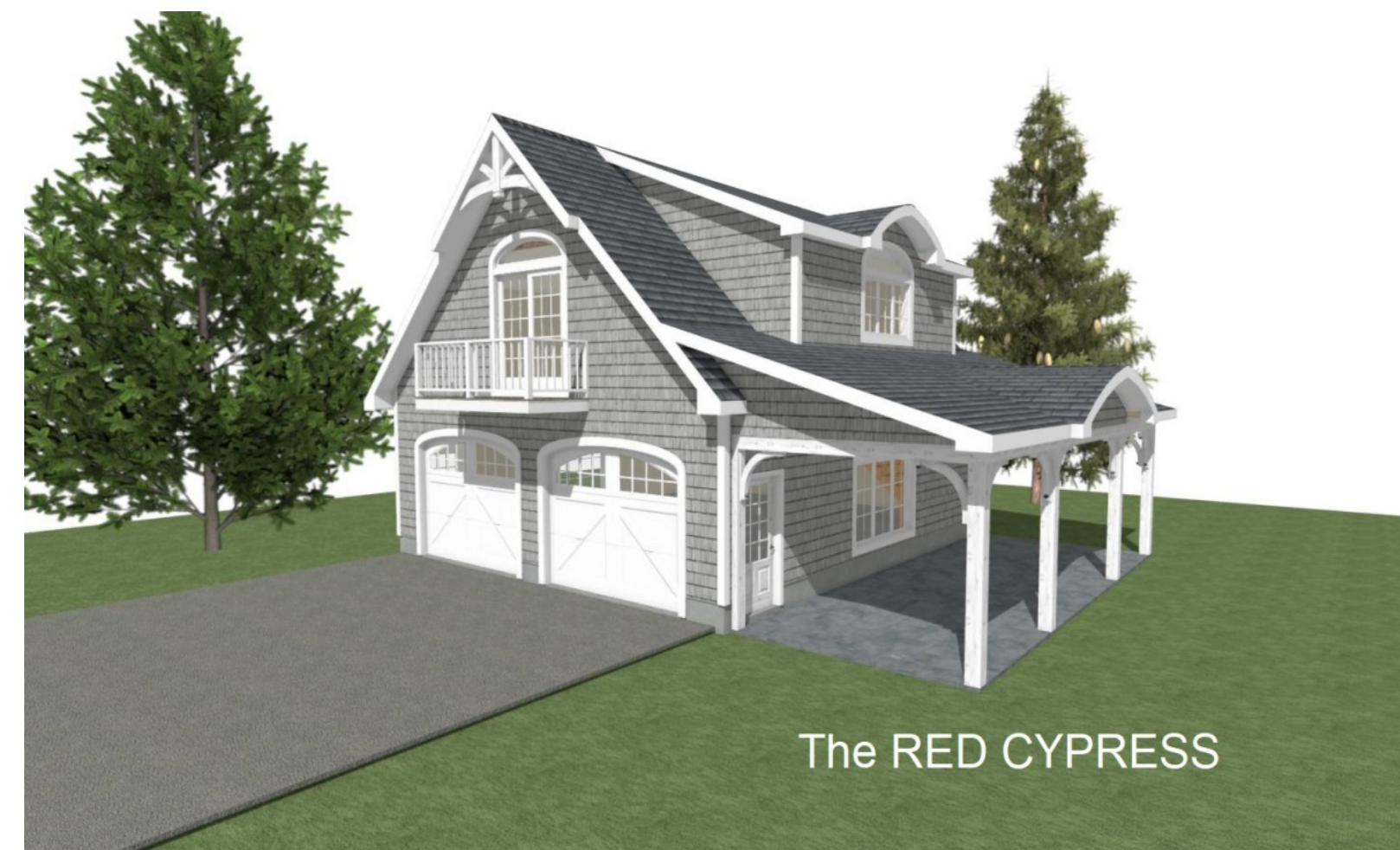

Custom Plans Available By Request

PLEASE CONSULT YOUR LOCAL BUILDING SUPPLIER
Open Your Mind to the Options

GOOD LUCK WITH YOUR PROJECT



" OPTIONS ARE ENDLESS "



NUMBER	DATE	REVISED BY	DESCRIPTION
1	9/2020	SH	Initial Setup
2	8/2020	SH	Launch Review
2	11/2021	SH	Upgrade 2021
1	10/2022	SH	Upgrade 2022



The HEMLOCK
24 x 24 Garage : 12/12
Gable Facing Doors

DRAWINGS PROVIDED BY:
Get My Garage
sheldon@fieldstonedesign.com
Custom Drawings Available

DATE:

12/22/2022

SCALE:

SHEET:

A - 14